

PN 5817
STK. NO. 19905

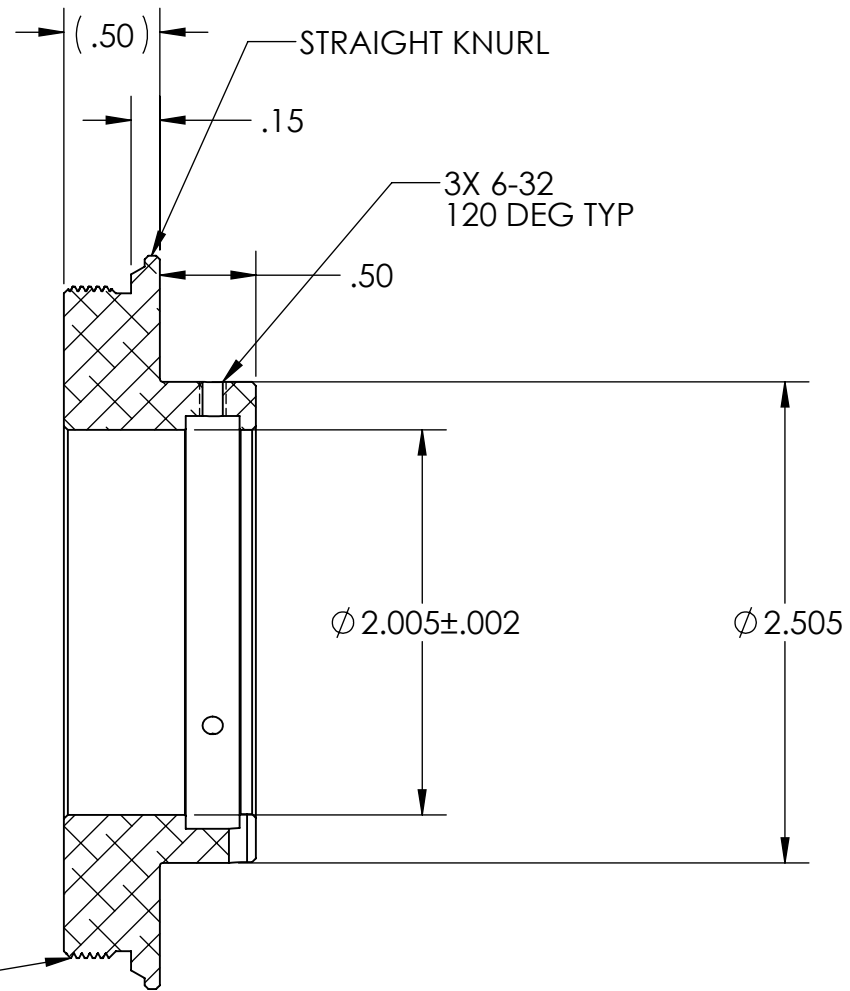

DSI 3.500 - 24 UNS-2A

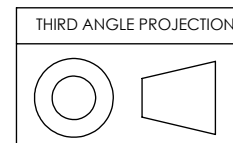
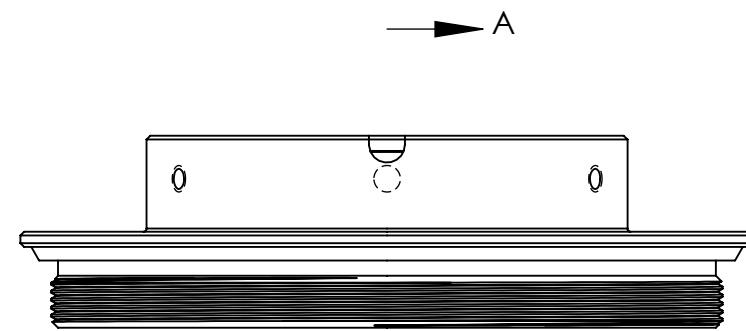
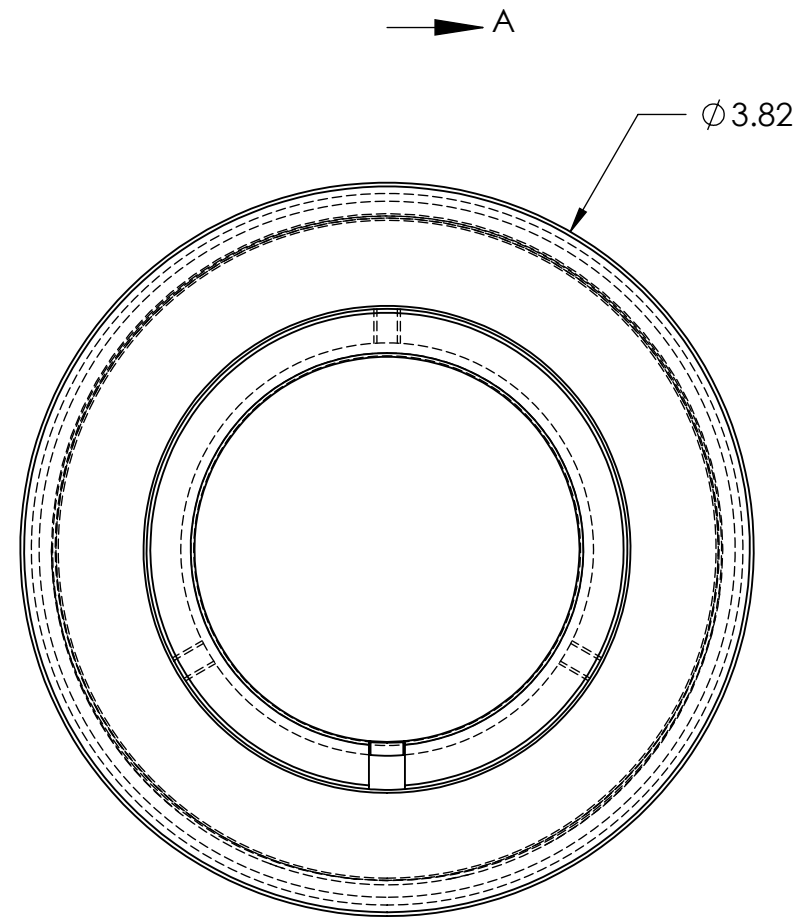

UNLESS OTHERWISE SPECIFIED: DIMENSIONS ARE IN INCHES TWO PLACE DECIMAL ±.007 THREE PLACE DECIMAL ±.003	DRAWN	NAME	DATE	Optec Inc.
	CHECKED	LD	10/27/15	
	ENG APPR.			
	MFG APPR.			
MATERIAL	6061-T6	CONTRACT		TITLE: DSI 3.500" - 24 TO 2" RECEIVER
FINISH	SEE NOTES	DSI		SIZE DWG. NO. B 19-06790
DO NOT SCALE DRAWING				SCALE: 1:1 WEIGHT: SHEET 1 OF 1