

PN 5051
 STK. NO.19896

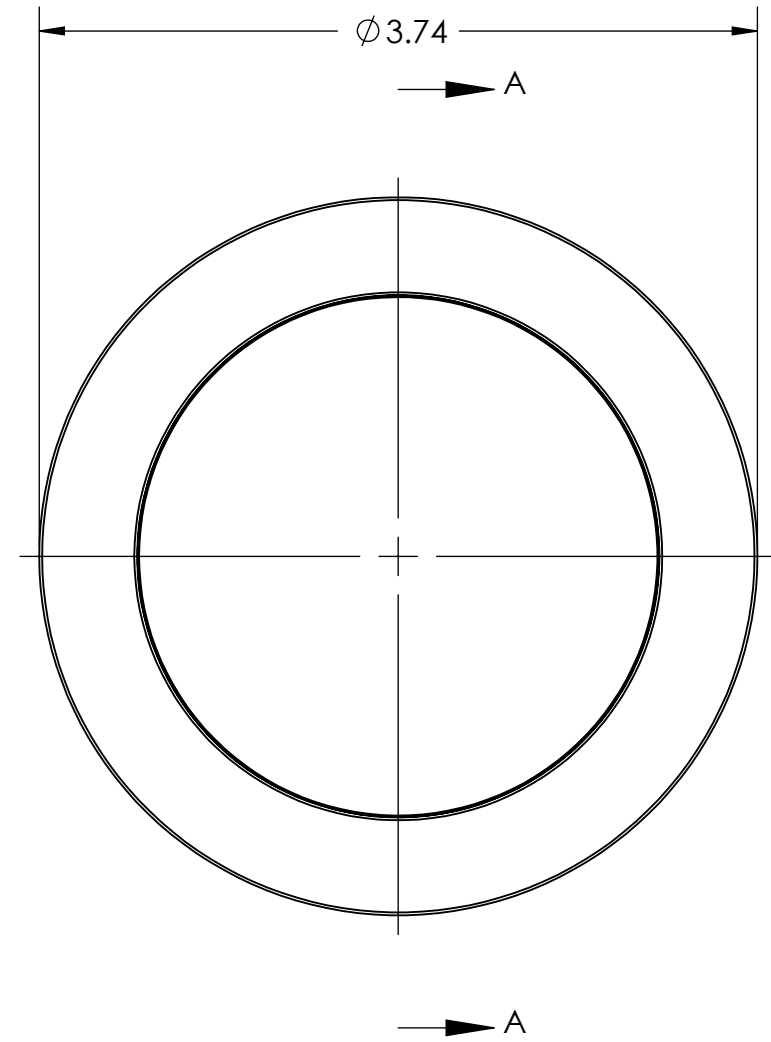
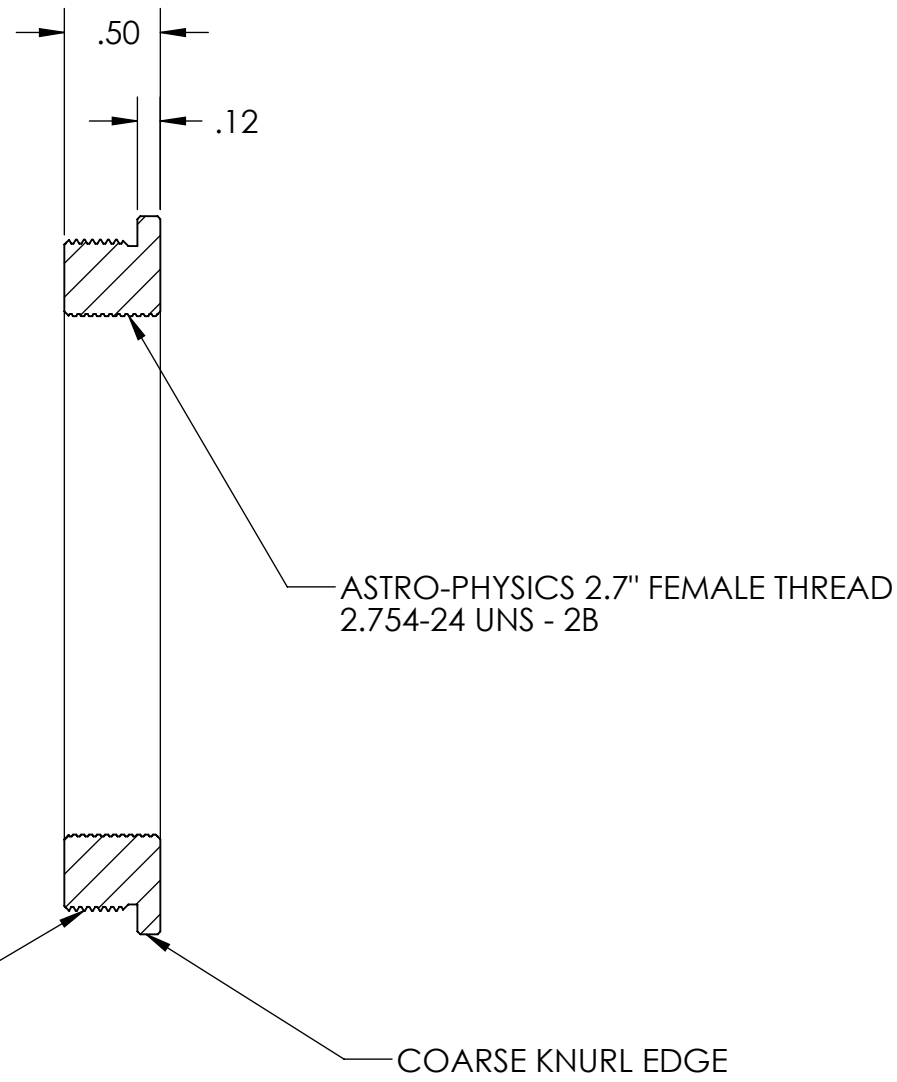

DSI 3.5 X 24TPI MALE

COARSE KNURL EDGE

REVISIONS				
ZONE	REV.	DESCRIPTION	DATE	APPROVED
	A	UPDATED THREAD SPEC ON DSI AND AP THREADS	2/20/2013	LD

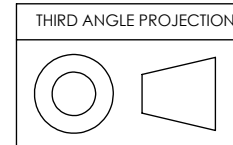

UNLESS OTHERWISE SPECIFIED: DIMENSIONS ARE IN INCHES TOLERANCES: FRACTIONAL ± ANGULAR: MACH ± BEND ± TWO PLACE DECIMAL ±.007 THREE PLACE DECIMAL ±.003	DRAWN	NAME	DATE	Optec Inc.
	CHECKED	BV	4/1/10	
	ENG APPR.			
	MFG APPR.			
MATERIAL	CONTRACT			TITLE:
FINISH	DSI 3.25 X 24 TPI			AP 2.7 FEMALE
DO NOT SCALE DRAWING	SIZE	DWG. NO.		
	B	19-06776		
	SCALE: 1:2	WEIGHT:	SHEET 1 OF 1	