

PN 5038  
STOCK NO. 19891

REVISIONS				
ZONE	REV.	DESCRIPTION	DATE	APPROVED
	A	REVISED DSI 3.5X24TPI THREAD SPECS. ADDED DETAIL B WITH 30-DEGREE CONTACT SURFACE FOR SELF-CENTERING SPACER SET.	3/21/2011	JD

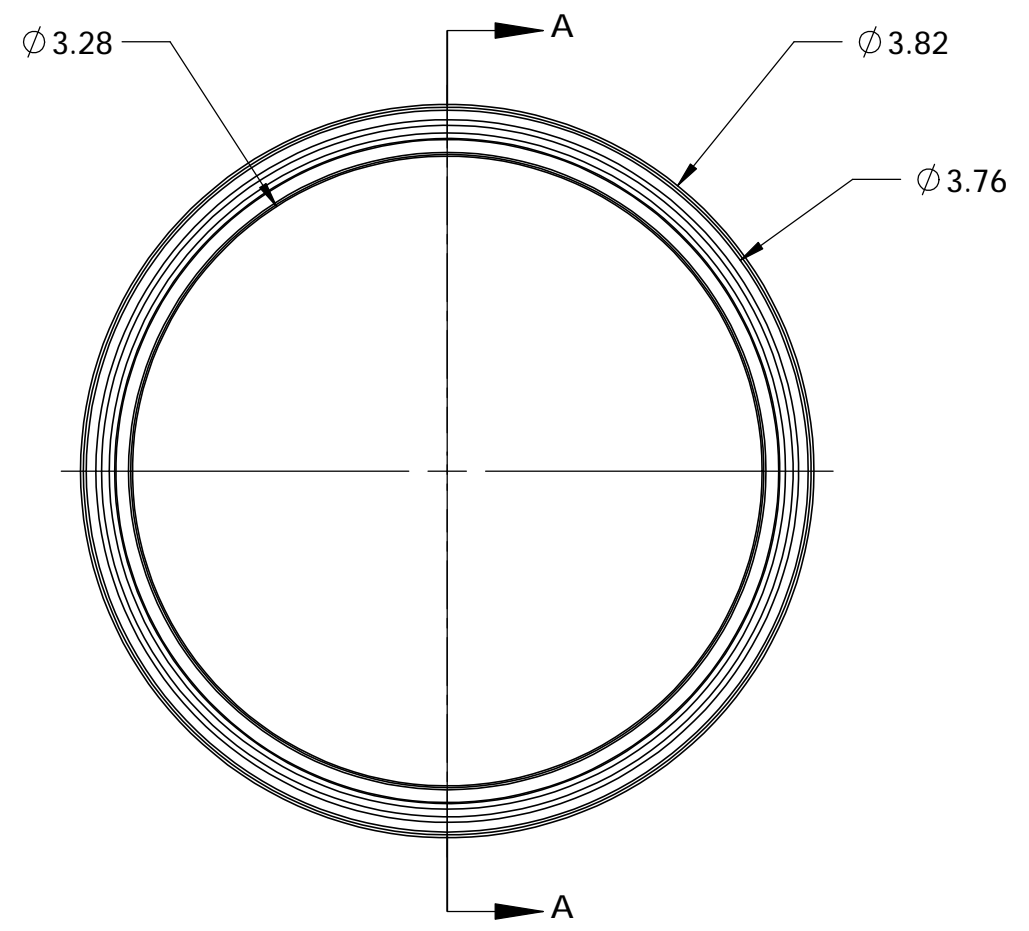
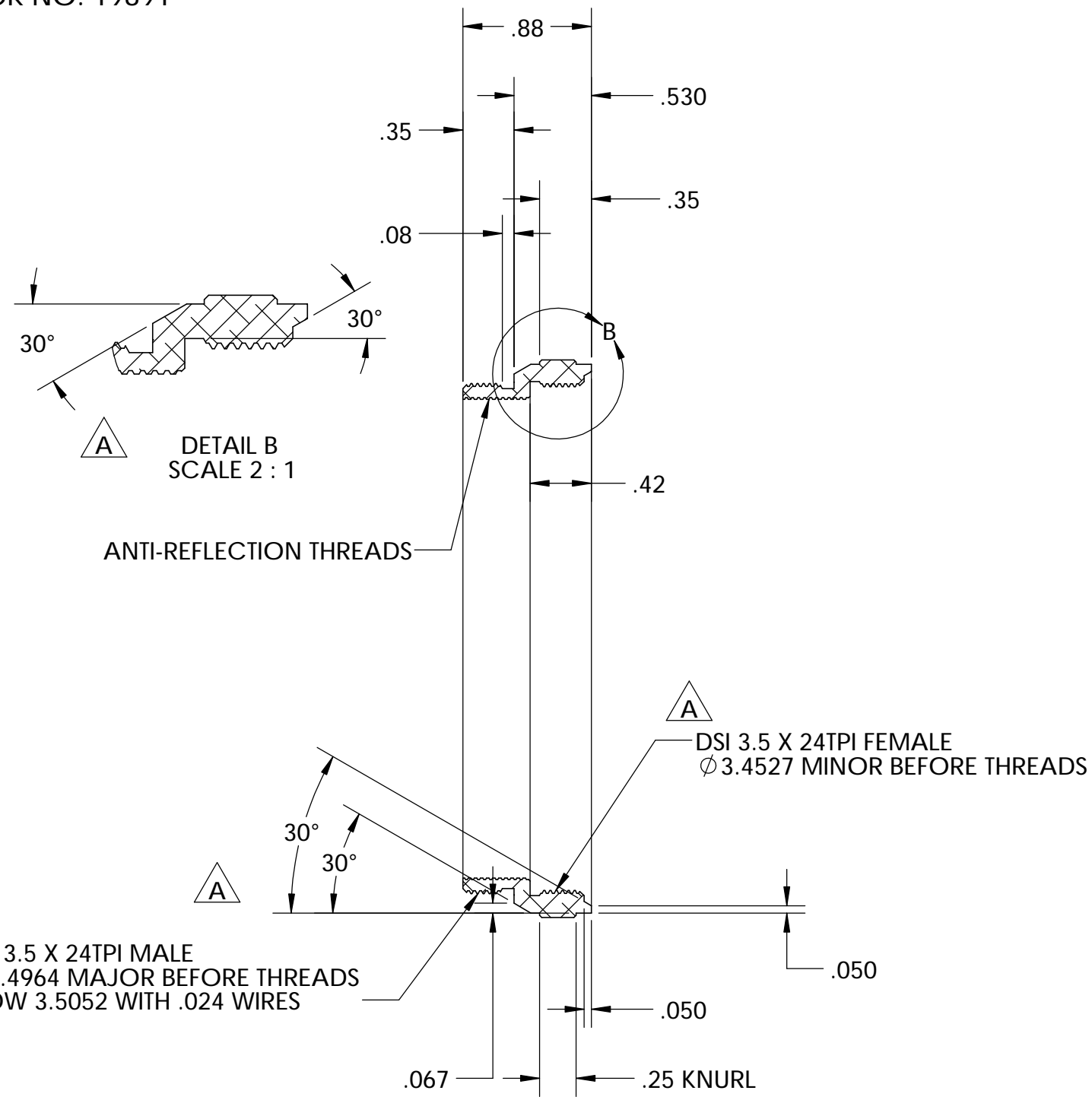

A DSI 3.5 X 24TPI MALE  
 $\phi$ 3.4964 MAJOR BEFORE THREADS  
MOW 3.5052 WITH .024 WIRES

UNLESS OTHERWISE SPECIFIED:  DIMENSIONS ARE IN INCHES TOLERANCES: FRACTIONAL $\pm$ ANGULAR: MACH $\pm$ BEND $\pm$ TWO PLACE DECIMAL $\pm$ .007 THREE PLACE DECIMAL $\pm$ .003	DRAWN	NAME	DATE
	CHECKED	BV	4/2/10
	ENG APPR.		
	MFG APPR.		
	Q.A.		
MATERIAL	6061-T6		
FINISH	SEE NOTES		
DO NOT SCALE DRAWING			

DRAWN		NAME		DATE		<b>Optec Inc.</b>	
CHECKED		BV		4/2/10		TITLE:	
ENG APPR.						1/2" EXTENSION	
MFG APPR.						SIZE	
Q.A.						DWG. NO.	
						<b>B</b>	
						<b>19-06771</b>	
						SCALE: 1:1	
						WEIGHT:	
						SHEET 1 OF 1	

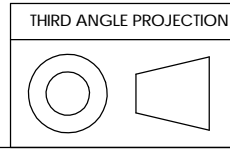

D  
C  
B  
A

D  
C  
B  
A

2 7 4 5 1 2 2 1

PN: 5039  
 STK No: 19892

REVISIONS				
ZONE	REV.	DESCRIPTION	DATE	APPROVED
	A	REVISED DSI 3.5X24TPI THREAD SPECS. ADDED DETAIL B WITH 30-DEGREE CONTACT SURFACE FOR SELF-CENTERING SPACER SET.	3/21/2011	JD

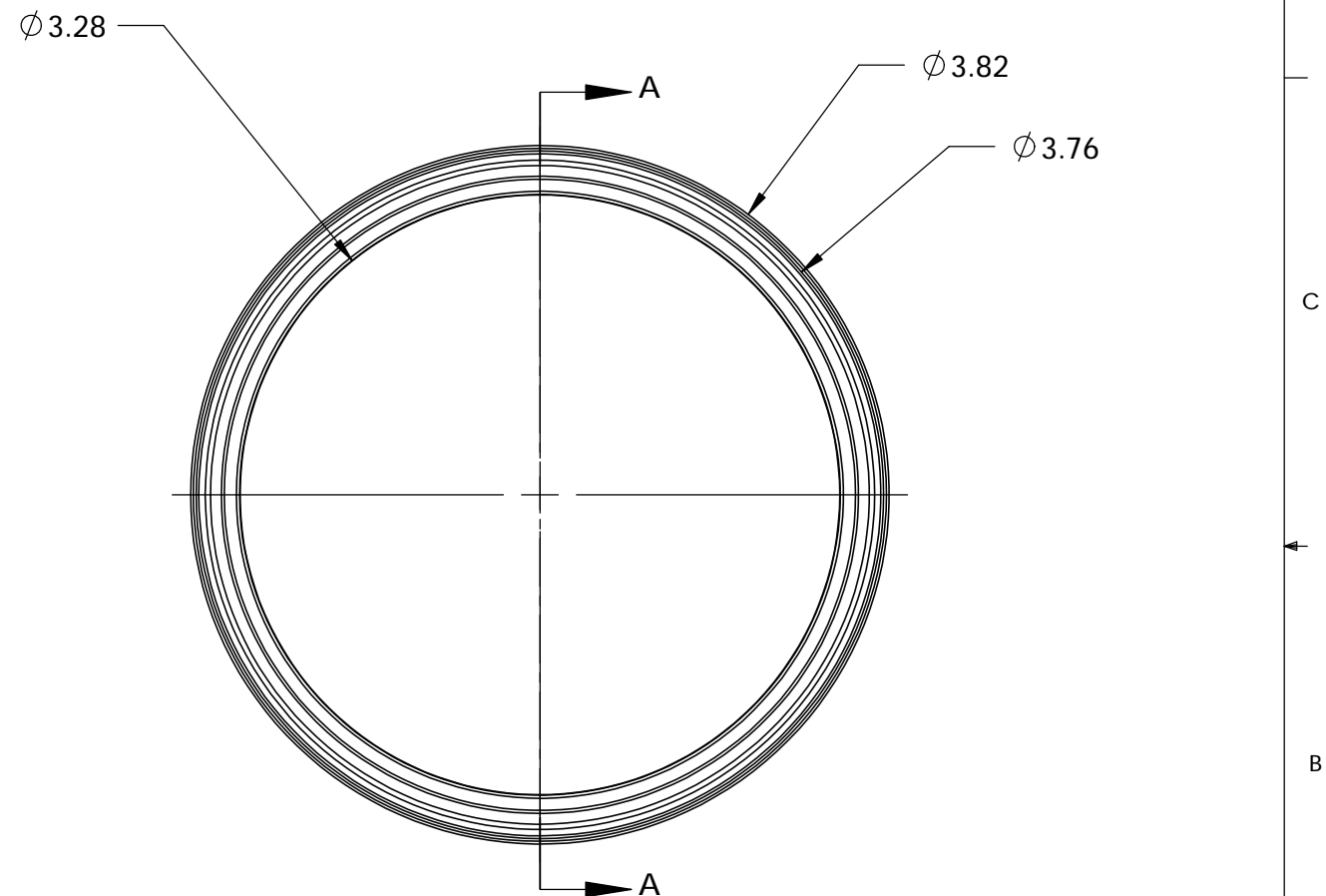
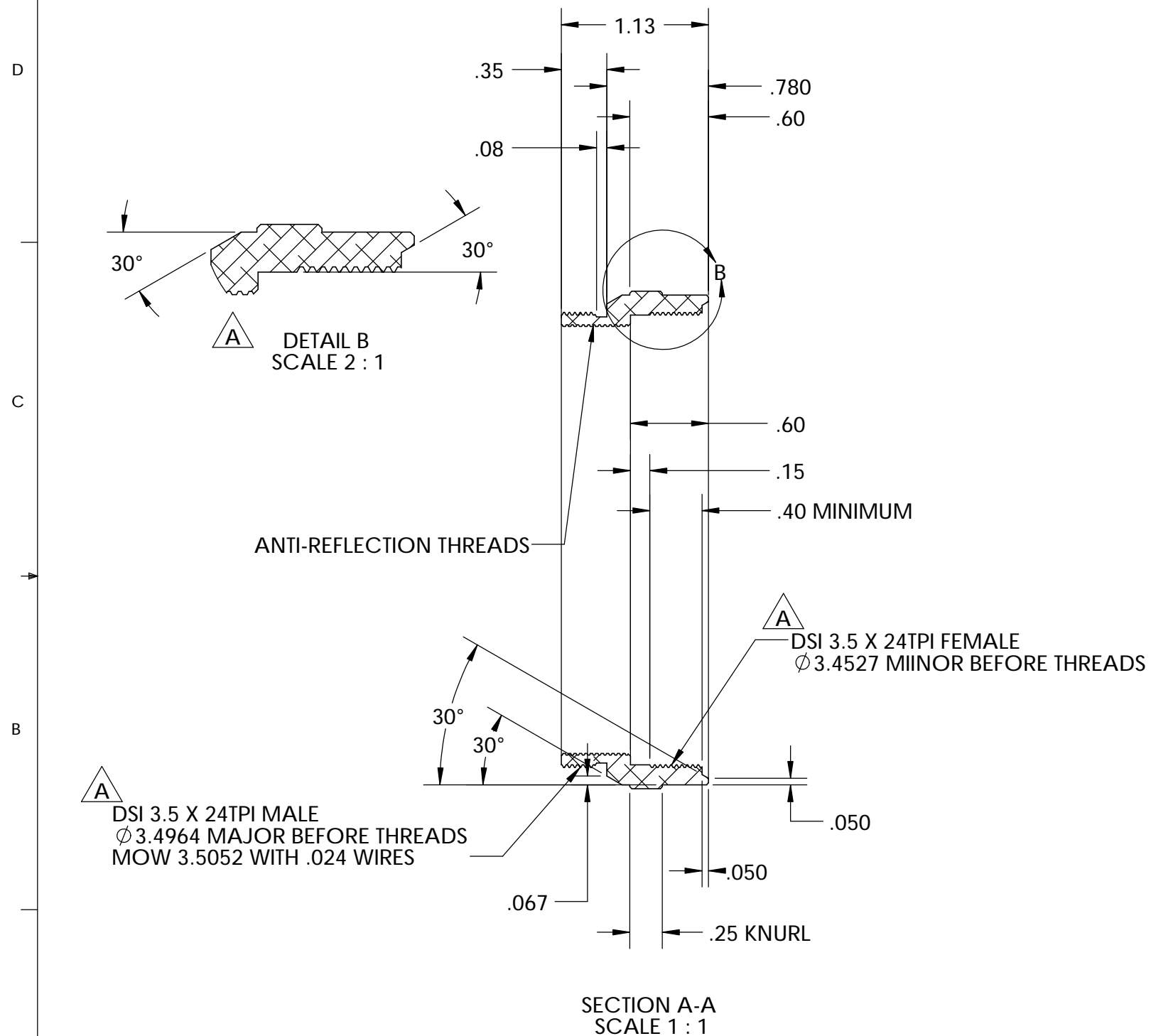

UNLESS OTHERWISE SPECIFIED: DIMENSIONS ARE IN INCHES TOLERANCES: FRACTIONAL ± ANGULAR: MACH ± BEND ± TWO PLACE DECIMAL ±.007 THREE PLACE DECIMAL ±.003	DRAWN	NAME	DATE	<b>Optec Inc.</b>
	CHECKED	BV	4/2/10	
	ENG APPR.			
	MFG APPR.			
MATERIAL	CONTRACT			TITLE:
6061-T6	DSI 3.5 X 24			3/4" EXTENSION
FINISH	SEE NOTES	SIZE	DWG. NO.	19-06772
DO NOT SCALE DRAWING		B		
		SCALE: 1:2	WEIGHT:	SHEET 1 OF 1

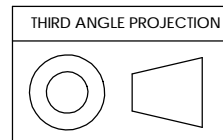

PN 5040  
STOCK NO. 19893

REVISIONS				
ZONE	REV.	DESCRIPTION	DATE	APPROVED
	A	REVISED DSI 3.5X24TPI THREAD SPECS. ADDED DETAIL B WITH 30-DEGREE CONTACT SURFACE FOR SELF-CENTERING SPACER SET.	3/21/2011	JD

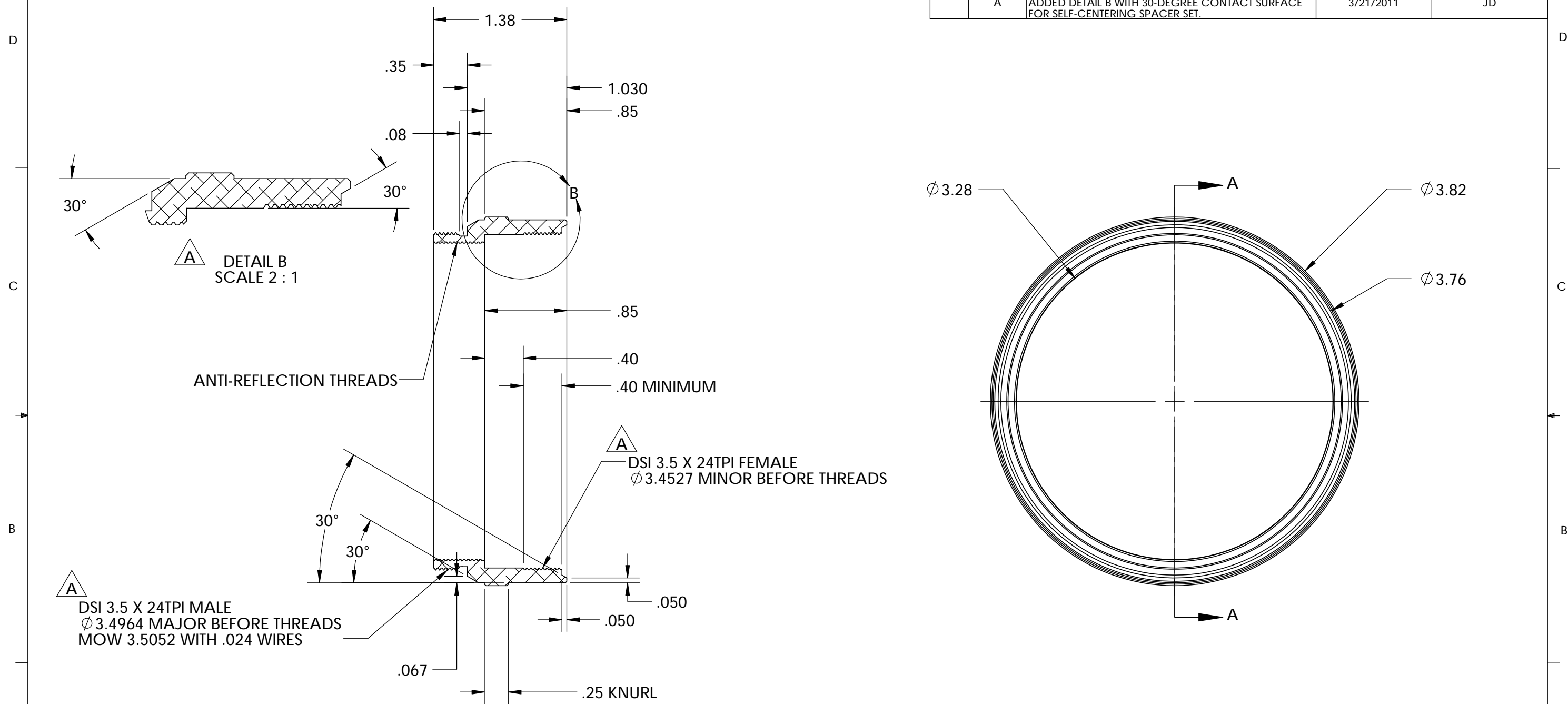

**A**  
DSI 3.5 X 24TPI MALE  
Ø 3.4964 MAJOR BEFORE THREADS  
MOW 3.5052 WITH .024 WIRES

**A**  
DETAIL B  
SCALE 2 : 1

SECTION A-A  
SCALE 1 : 1

**A**  
DSI 3.5 X 24TPI FEMALE  
Ø 3.4527 MINOR BEFORE THREADS

UNLESS OTHERWISE SPECIFIED:	DRAWN	NAME	DATE
	CHECKED	BV	4/2/10
	ENG APPR.		
	MFG APPR.		
		Q.A.	
MATERIAL	CONTRACT		
6061-T6	DSI 3.5 X 24		
FINISH	SEE NOTES		
DO NOT SCALE DRAWING			

<b>Optec Inc.</b>		
TITLE:		
1" EXTENSION		
SIZE	DWG. NO.	
<b>B</b>	<b>19-06773</b>	
SCALE: 1:2	WEIGHT:	SHEET 1 OF 1

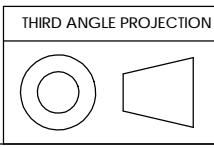

PN 5041  
STOCK NO. 19894

REVISIONS				
ZONE	REV.	DESCRIPTION	DATE	APPROVED
	A	REVISED DSI 3.5X24TPI THREAD SPECS. ADDED DETAIL B WITH 30-DEGREE CONTACT SURFACE FOR SELF-CENTERING SPACER SET.	3/21/2011	JD

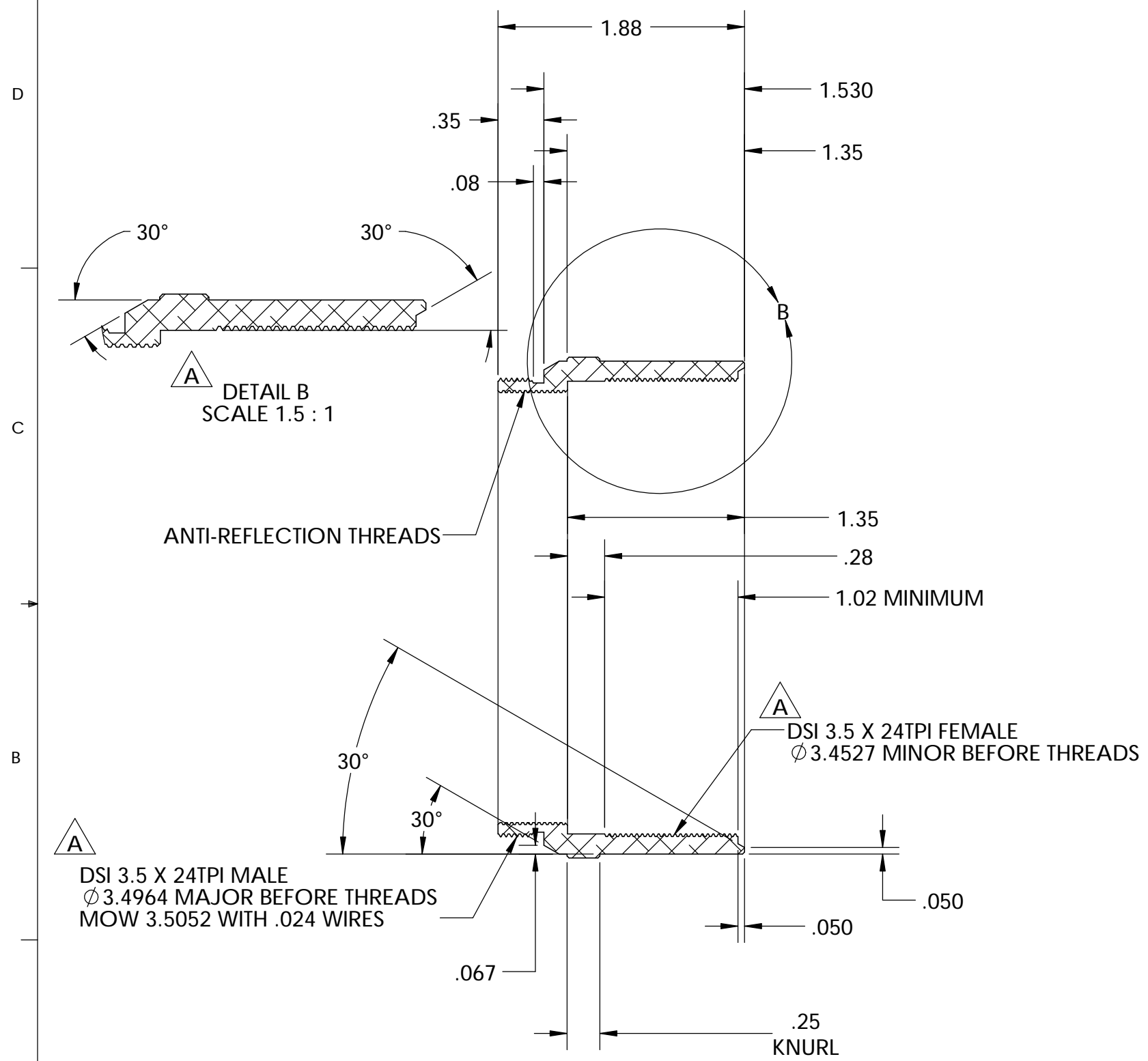

SECTION A-A  
SCALE 1 : 1

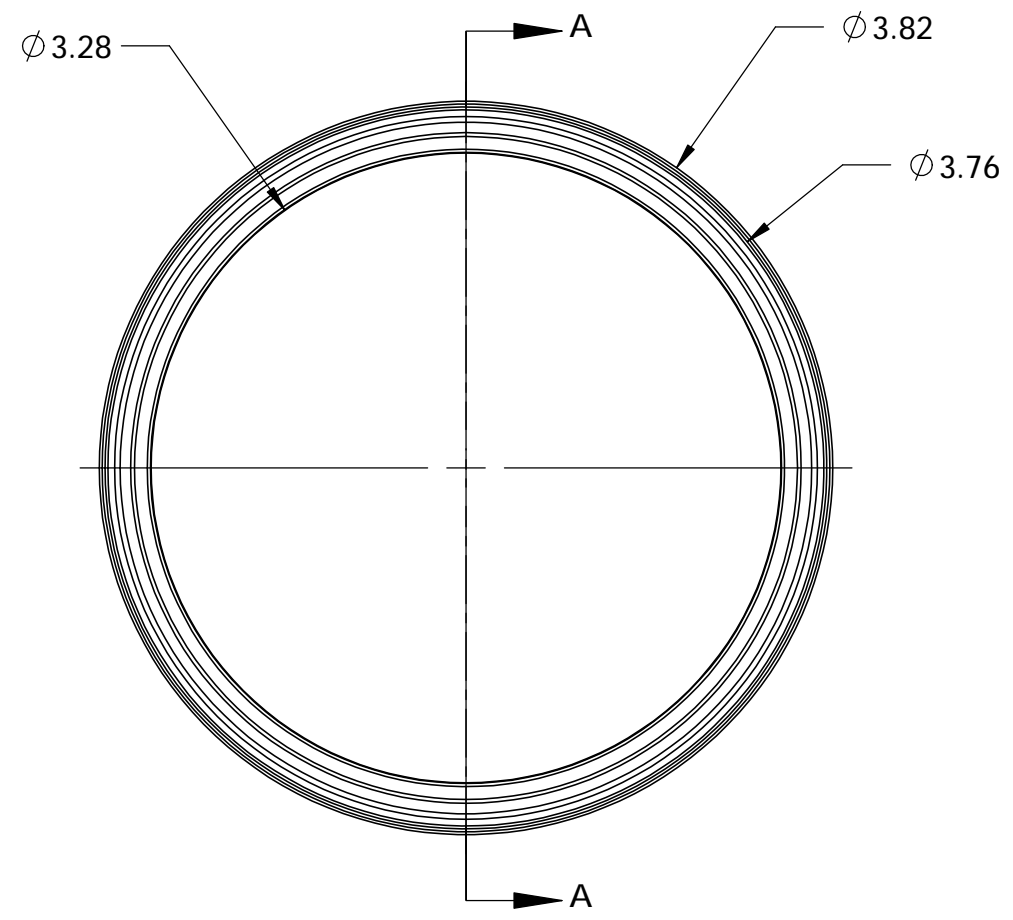

DSI 3.5 X 24TPI MALE  
Ø 3.4964 MAJOR BEFORE THREADS  
MOW 3.5052 WITH .024 WIRES

DSI 3.5 X 24TPI FEMALE  
Ø 3.4527 MINOR BEFORE THREADS

UNLESS OTHERWISE SPECIFIED: DIMENSIONS ARE IN INCHES TOLERANCES: FRACTIONAL ± ANGULAR: MACH ± BEND ± TWO PLACE DECIMAL ±.007 THREE PLACE DECIMAL ±.003	DRAWN	NAME	DATE	<b>Optec Inc.</b>
	CHECKED	BV	4/2/10	
	ENG APPR.			
	MFG APPR.			
MATERIAL	CONTRACT			TITLE: <b>1-1/2" EXTENSION</b>
6061-T6	DSI 3.5 X 24			
FINISH	SEE NOTES	SIZE	DWG. NO.	<b>B</b> <b>19-06774</b>
DO NOT SCALE DRAWING		SCALE: 1:2	WEIGHT:	
				SHEET 1 OF 1

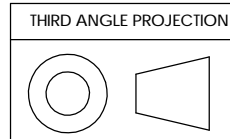

PN 5050  
STOCK NO. 19895

REVISIONS				
ZONE	REV.	DESCRIPTION	DATE	APPROVED
	A	REVISED DSI 3.5X24TPI THREAD SPECS. ADDED DETAIL B WITH 30-DEGREE CONTACT SURFACE FOR SELF-CENTERING SPACER SET.	3/21/2011	JD

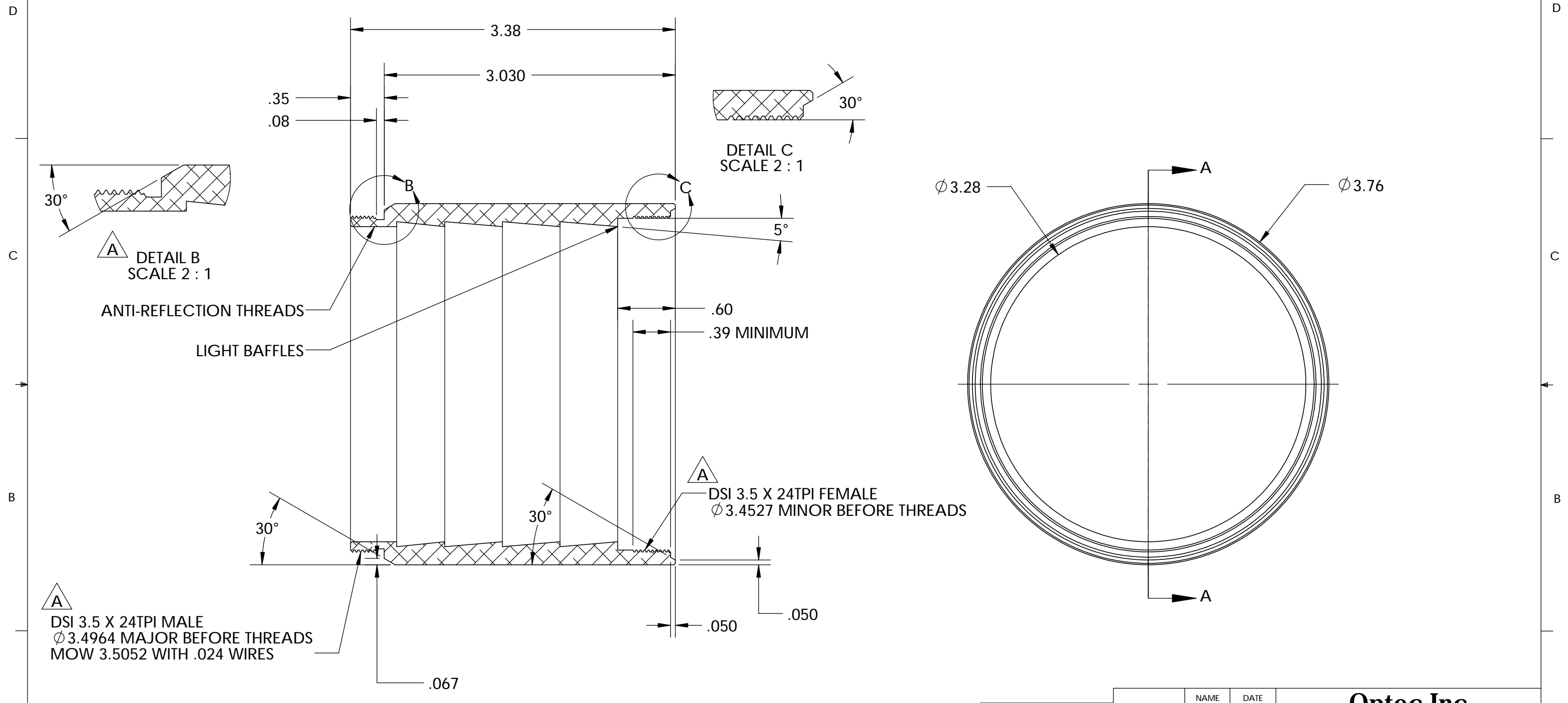

UNLESS OTHERWISE SPECIFIED:		DRAWN	NAME	DATE	<b>Optec Inc.</b>
DIMENSIONS ARE IN INCHES TOLERANCES: FRACTIONAL ± ANGULAR: MACH ± BEND ± TWO PLACE DECIMAL ±.007 THREE PLACE DECIMAL ±.003		CHECKED	BV	4/2/10	
MATERIAL		ENG APPR.			
FINISH		MFG APPR.			
DO NOT SCALE DRAWING		CONTRACT			TITLE:
		DSI 3.5 X 24			3" EXTENSION
		SIZE	DWG. NO.		
		<b>B</b>	<b>19-06775</b>		
		SCALE: 1:2	WEIGHT:	SHEET 1 OF 1	