

STK NO 19809

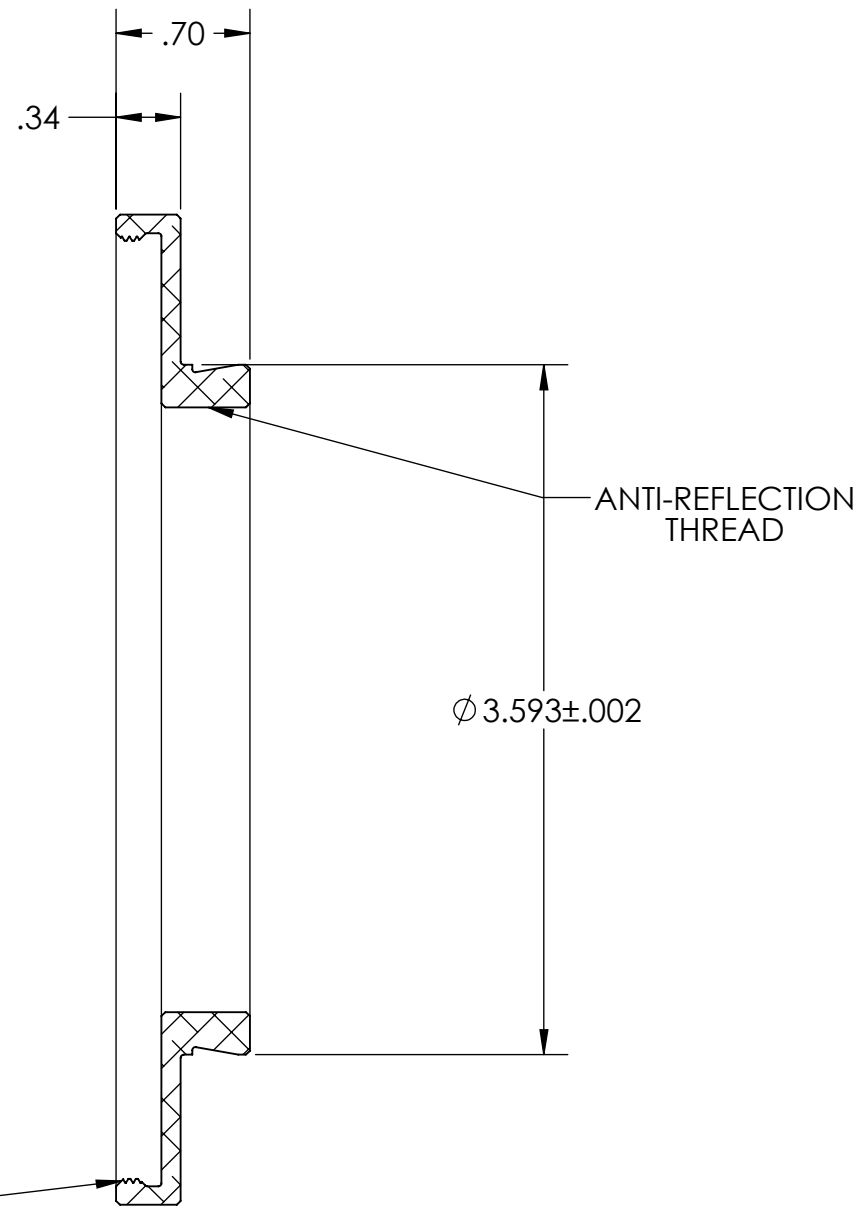

SECTION A-A

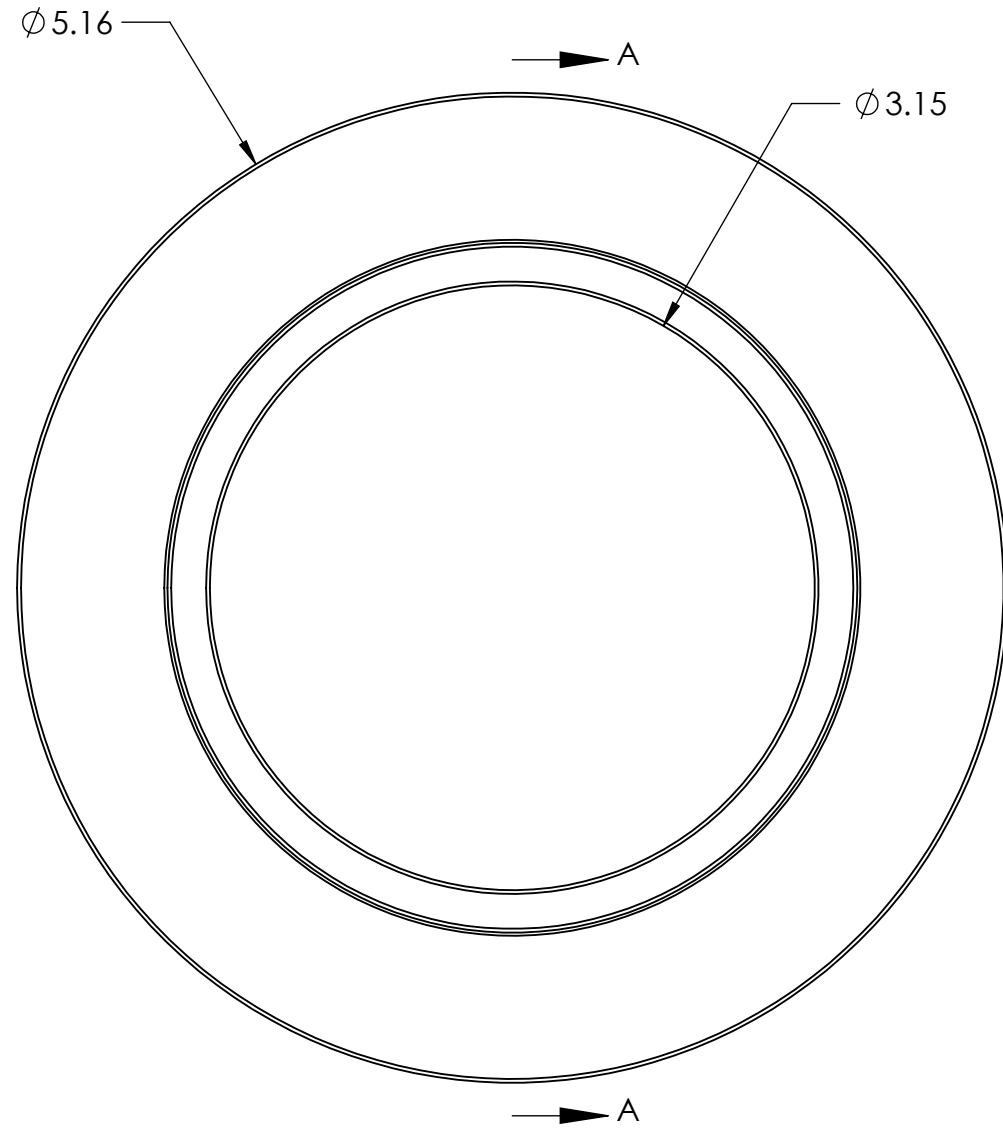

UNLESS OTHERWISE SPECIFIED: DIMENSIONS ARE IN INCHES TWO PLACE DECIMAL $\pm .007$ THREE PLACE DECIMAL $\pm .003$	DRAWN	NAME	DATE	Optec Inc.
	CHECKED	LD	01/18/12	
	ENG APPR.			
	MFG APPR.			
MATERIAL: 6061-T6	Q.A.			TITLE: M125X1mm FEMALE TO OPTEC 3600
STOCK SIZE: 0.00 X 0.00 X .00	CONTRACT			SIZE DWG. NO. B 17-06889
FINISH SEE NOTES	OPTEC-3600			SCALE: 1:1 WEIGHT: SHEET 1 OF 1
DO NOT SCALE DRAWING				

