

PN 5097
 STK. NO. 19805

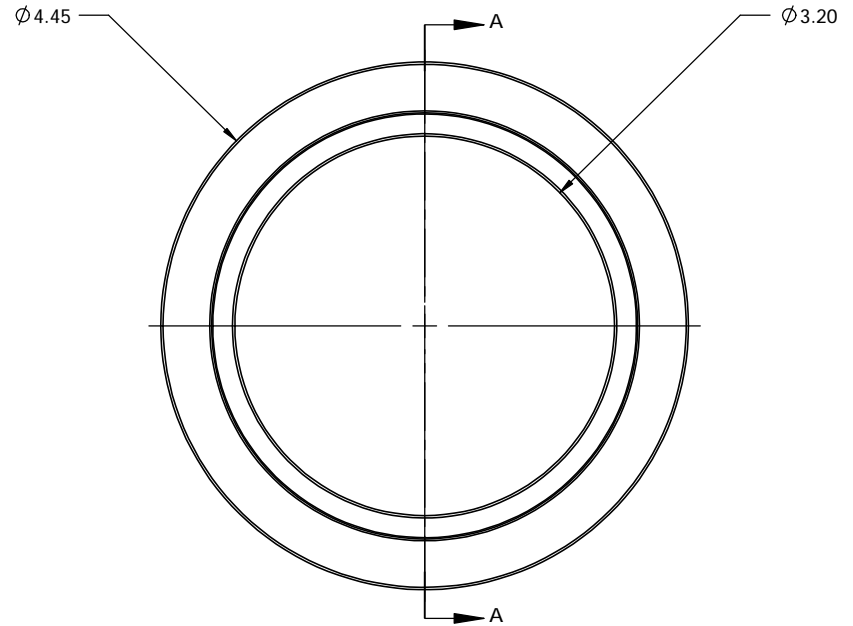

UNLESS OTHERWISE SPECIFIED:		DRAWN	NAME	DATE	Optec Inc.	
		LD		05/17/10		
DIMENSIONS ARE IN INCHES		CHECKED	TITLE: FLI ATLAS TO OPTEC 3600			
TOLERANCES:		ENG APPR.				
FRACTIONAL ±		MFG APPR.				
ANGULAR: MACH ± BEND ±		Q.A.				
TWO PLACE DECIMAL ±.007		CONTRACT			SIZE	DWG. NO.
THREE PLACE DECIMAL ±.003		OPTEC 3600			B	17-06884
MATERIAL		DO NOT SCALE DRAWING			SCALE: 1:1	WEIGHT:
FINISH: SATIN ETCH BLACK					SHEET 1 OF 1	

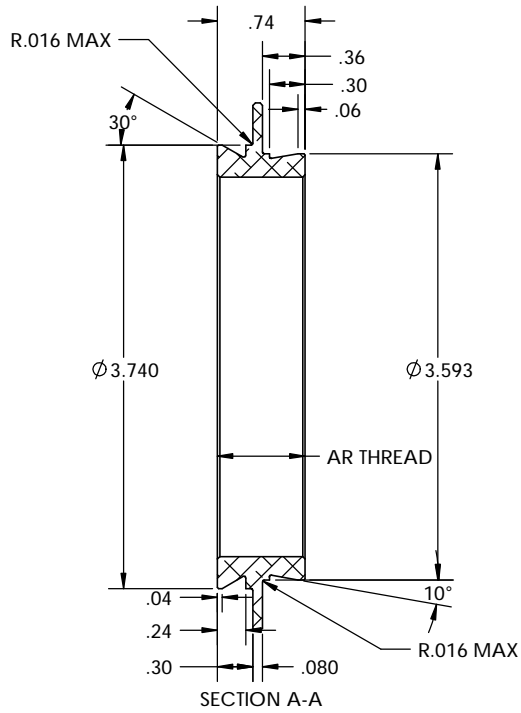