

PN 5010
STK. NO. 19662

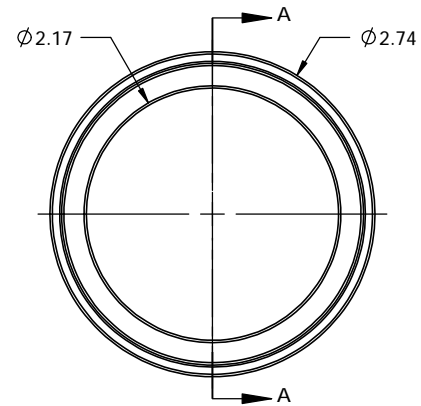
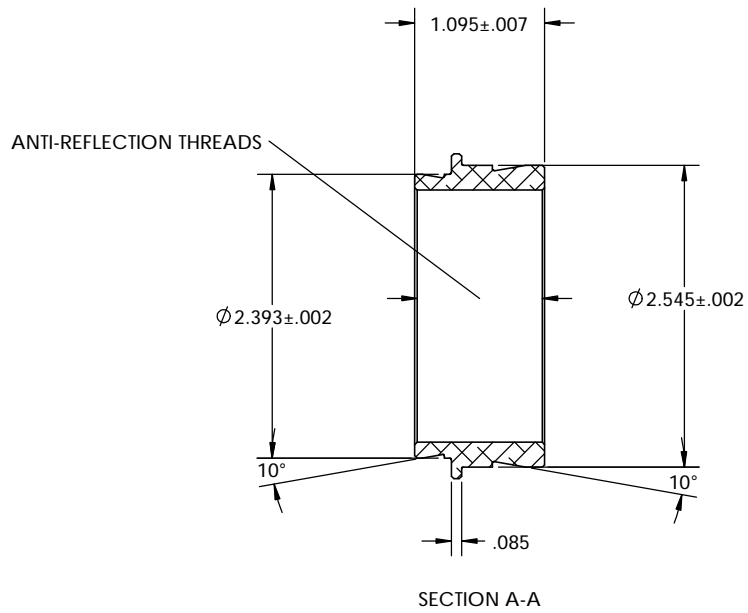

THIRD ANGLE PROJECTION		UNLESS OTHERWISE SPECIFIED:		DRAWN	NAME	DATE	Optec Inc.	
		DIMENSIONS ARE IN INCHES		LD	LD	11/13/09		
		TOLERANCES:		CHECKED				TITLE:
		FRACTIONAL ±		ENG APPR.				
		ANGULAR: MACH ± BEND ±		MFG APPR.				OPTEC-2400
TWO PLACE DECIMAL ±.007		G.A.					SIZE DWG. NO.	
THREE PLACE DECIMAL ±.003		CONTRACT		OPTEC-2400			B 17-06705	
MATERIAL		6061-T6				SCALE: 1:1	WEIGHT:	
FINISH		SEE NOTES				SHEET 1 OF 1		
DO NOT SCALE DRAWING								