

PN 5006
STOCK NO 19652

C-THREAD

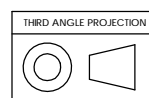
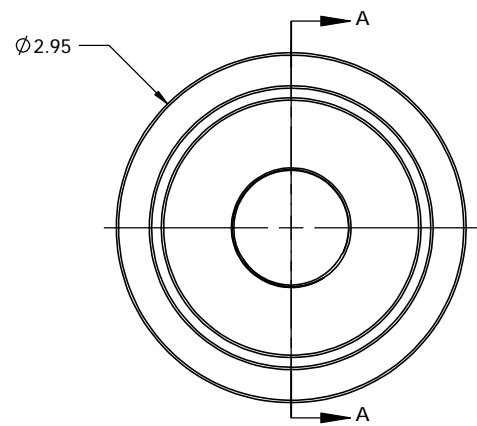
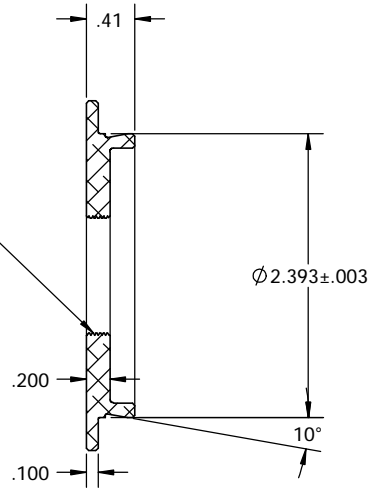

UNLESS OTHERWISE SPECIFIED: DIMENSIONS ARE IN INCHES TOLERANCES: FRACTIONAL ± ANGULAR: MACH ± BEND ± TWO PLACE DECIMAL ±.007 THREE PLACE DECIMAL ±.003	DRAWN	NAME	DATE	Optec Inc. TITLE: FEMALE C-MOUNT TO OPTEC-2400
	CHECKED	LD	10/15/09	
	ENG APPR.			
	MFG APPR.			
MATERIAL	CONTRACT			SIZE DWG. NO. B 17-06338
6061-T6	OPTEC-2400			
FINISH FROSTKOTE BRIGHT DIP BLACK				SCALE: 1:1 WEIGHT: SHEET 1 OF 1
DO NOT SCALE DRAWING				