

PN: 5054
 STK No: 19370

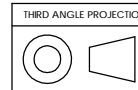
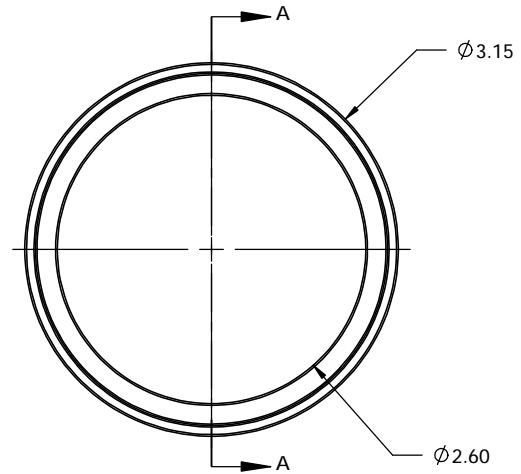
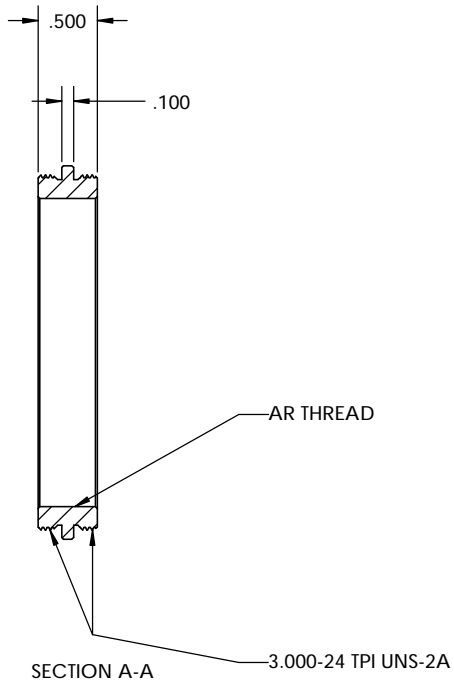

UNLESS OTHERWISE SPECIFIED: DIMENSIONS ARE IN INCHES TOLERANCES: FRACTIONAL ± ANGULAR: MACH ± BEND ± TWO PLACE DECIMAL ±.007 THREE PLACE DECIMAL ±.003	DRAWN	NAME	DATE	Optec Inc.
	CHECKED	BV	4/5/10	
	ENG APPR.			
	MFG APPR.			
	Q.A.			TITLE: MALE TO MALE MOUNT
MATERIAL 6061-T6	CONTRACT			SIZE DWG. NO.
FINISH FROSTKOTE BRIGHT DIP BLACK	3"X24TPI ADAPTERS			B 19-03810
DO NOT SCALE DRAWING				SCALE: 1:1 WEIGHT: SHEET 1 OF 1