

PN 4575
STK NO 17812

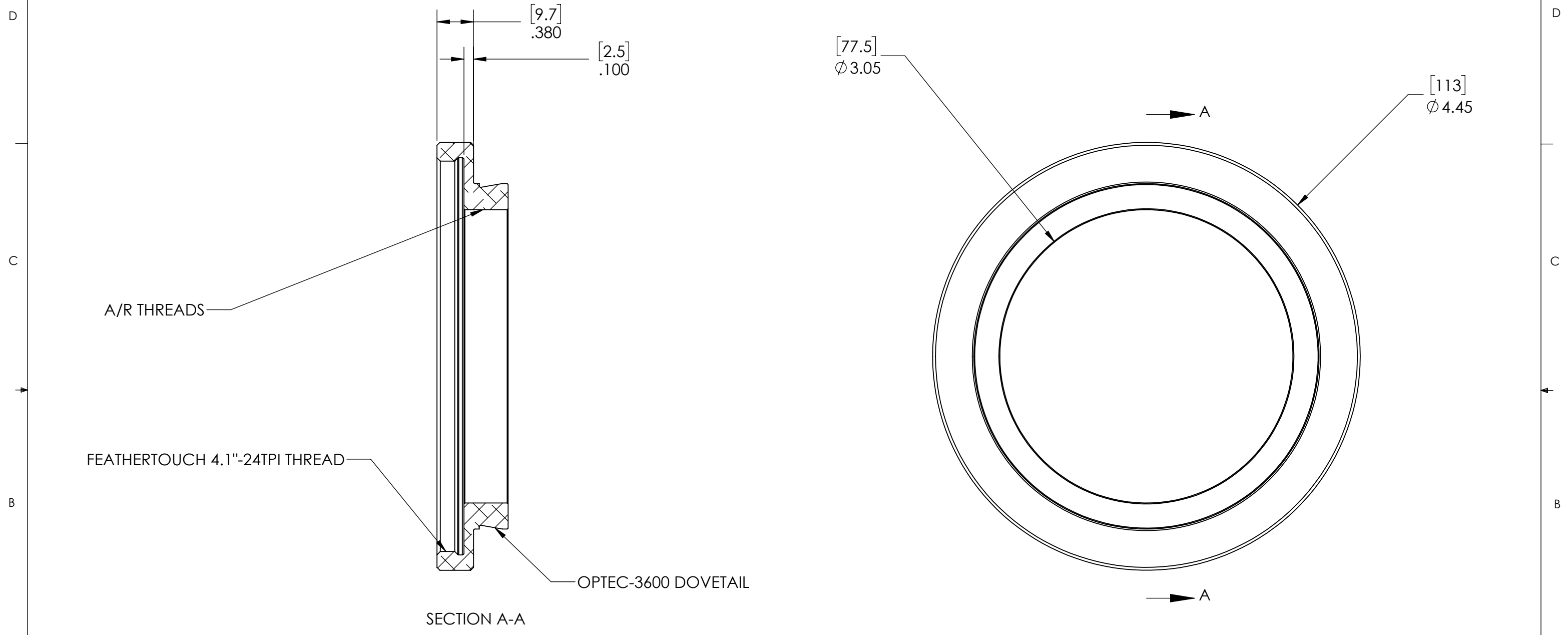

UNLESS OTHERWISE SPECIFIED: DIMENSIONS ARE IN INCHES TOLERANCES: FRACTIONAL ± ANGULAR: MACH ± BEND ± TWO PLACE DECIMAL ±.007 THREE PLACE DECIMAL ±.003	DRAWN	NAME	DATE	Optec Inc. TITLE: STARLIGHT 3.5" MOUNT
	CHECKED	LD	2/2/11	
	ENG APPR.			
	MFG APPR.			
	Q.A.			
	CONTRACT			
MATERIAL	6061-T6			SIZE
FINISH	SEE NOTES			DWG. NO.
	DO NOT SCALE DRAWING			B 17-06673
		OPTEC-3600		SCALE: 1:1
				WEIGHT:
				SHEET 1 OF 1

