

STK. NO. 17665

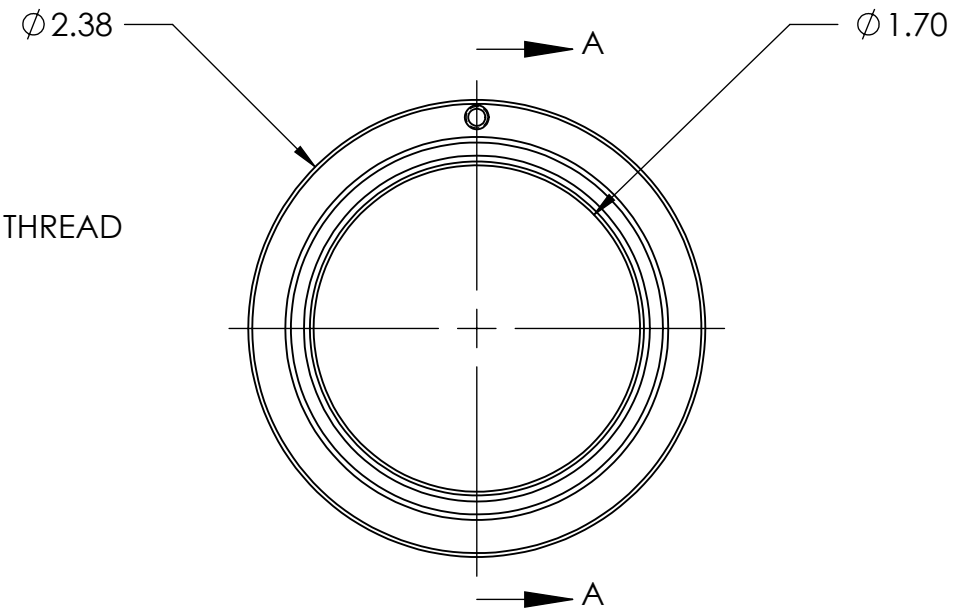

SECTION A-A

UNLESS OTHERWISE SPECIFIED: DIMENSIONS ARE IN INCHES TOLERANCES: FRACTIONAL ± ANGULAR: MACH ± BEND ± TWO PLACE DECIMAL ±.007 THREE PLACE DECIMAL ±.003	DRAWN	NAME	DATE	<b>Optec Inc.</b> TITLE: <b>2-INCH TO SCT LONG THREAD</b>	
	CHECKED	LD	06/15/10		
	ENG APPR.				
	MFG APPR.				
	Q.A.				
	CONTRACT				
	2-INCH ADAPTERS				
	MATERIAL	6061-T6		SIZE	
	FINISH	FROSTKOTE BRIGHT DIP BLACK		DWG. NO.	
	DO NOT SCALE DRAWING			<b>B</b>	<b>17-06619</b>
		SCALE: 1:1	WEIGHT:	SHEET 1 OF 1	

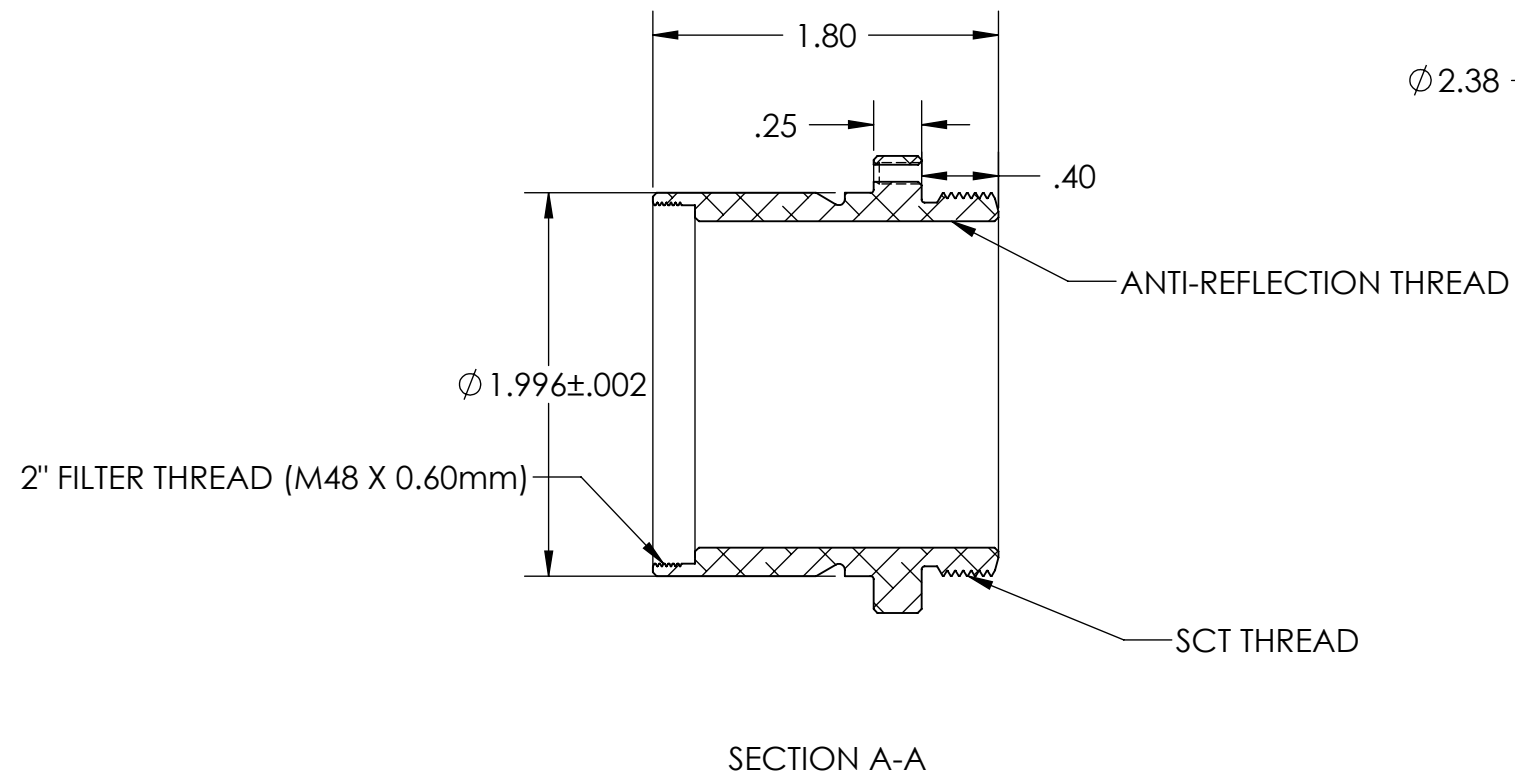